

The PRO-HHD is designed for use on large industrial sectional doors with high or vertical lift track and rolling doors and grilles.

## STANDARD FEATURES

- 2 year Warranty
- **3 Control Circuit Options Available:**
- \* **1- (M)** Heavy duty reversing contactor with mechanical & electrical interlock incorporating the new UL325 (2010) Interface Module.
  - \*C2 factory wiring standard (constant pressure close), B2 wiring can be field set by moving 1 jumper and installing Micanan monitored fail safe photo-eyes (supplied) or (optional) Micanan compatible monitored fail safe electric edge
- \* **2- (E)** Full Function Smart 10.0 Logic control board featuring on-board receiver with antenna, enhanced program selections to include B2, C2, D1, E2, T & TS and supplied with Micanan monitored fail safe photo-cells or (optional) Micanan monitored fail safe electric edge
  - \*D1 factory pre-set mode of operation standard (constant pressure open & close)
- 3-** Heavy duty reversing contactor with mechanical & electrical interlock. (Not available in US or other areas where UL325 (2010) is mandated) C2 factory wiring standard, B2 wiring can be field set by moving 1 jumper. Provisions for standard reversing devices.
- 24V class 2 control circuit with 40VA transformer to protect against short circuit
- External radio control terminal strip
- Low friction powder metal limit cam nuts with fully adjustable rotary type limit switch assembly
- Three button open-close-stop control station Nema-1
- Continuous duty industrial motor with overload protection
- Motor removable without affecting limit settings
- Heavy duty 5L V-belt
- #41 roller chain & sprockets on all internal drives
- Adjustable friction clutch
- Solenoid brake standard
- #50 roller chain and sprockets on final drive
- 3/4" precision flanged ball bearings permanently lubricated & sealed on pulley shaft
- Second and final stage of reduction cast iron 1" flanged bearings permanently sealed and lubricated
- Emergency chain hoist with electrical cut-out switch for manual operation
- Chain keeper
- Left or right hand mounting (must specify at time of order)
- Baked on dark grey coat finish
- Shipping weight 110 lbs



Industrial continuous duty belt drive jackshaft operator with emergency chain hoist

## When ordering a PRO-HHD operator, supply Micanan with the following information

- Door height
- Door width
- Type of door
- Horsepower
- Voltage/Phase
- Safety devices
- Door shaft diameter & door shaft key size
- Mounting (LH or RH, Bracket or Wall mount)
- Options

## MECHANICAL DIMENSIONS

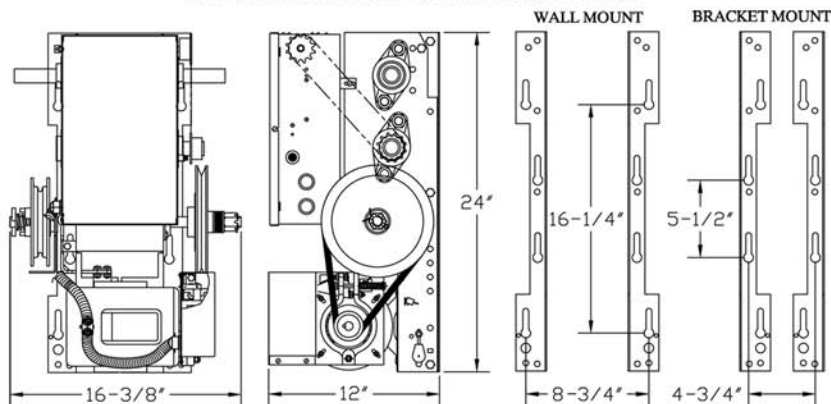

## NEW SMART 10.0 LOGIC BOARD



- On-board open, close, stop pushbuttons
- Built-in 372 Mhz radio receiver
- Programable timer to close
- Programable mid stop
- Maximum run timer
- 1.5 sec time delay reverse
- Programable delay on close
- On-board fuse protection
- Plug in board option
- New vision lights

FOR MORE INFORMATION, PLEASE VISIT [WWW.MICANAN.COM](http://WWW.MICANAN.COM) OR CONTACT US AT